

# primus

## Industrial Cylinder Heated Drying Ironers with Integrated Feeding and Length Folding IFF 50



### FEATURES

- Large surface contact with linen over an angle of 300°
- Chrome-plated cylinder for a better thermal conduction
- Finger protection and emergency button for more safety
- Durable NOMEX ironing belts
- Automatic cooldown
- Easy to operate microprocessor: 20 pre-set ironing programmes
- Indication of ironing speed and temperature
- Reverse mode possible
- Variable setups for folding
- Built-in feeding and length folding system
- Frequency controlled motor
- Easy to remove lint filters
- Standard anti-static bar
- Foot pedal for easy operation
- Easyfold® system requires less maintenance (no ribbons and rolls)
- Electric, gas or steam heating

### OPTIONS

- Crossfolder and stacker

**EASYFOLD®**

TYPE		IFF 50-200	IFF 50-250	IFF 50-320
Roller diameter	mm	500	500	500
Useful roller length	mm	2000	2500	3200
<b>HEATING</b>				
Electric heating	kW	37,2	70,2	-
Gas heating	kW	36	52	66
Steam heating	kg/h	49	68	88
<b>MOTOR</b>				
Roller motor	kW	0,98	1,2	1,2
Fan motor	kW	0,18/0,255	2x0,18/0,255	2x0,18/0,255
<b>CAPACITY*</b>	kg/h	50	70	90
<b>ROLLER SPEED</b>	m/min.	1,5-8	1,5-8	1,5-8
<b>ELECTRICAL CONNECTION</b>		3+PE+N 380-415V 50/60Hz 3+PE 208-240V 50/60Hz		
<b>COMPRESSED AIR CONNECTION**</b>	inch	exterior: 1/2 - interior: 1/4		
<b>DIMENSIONS</b>				
Ironer HxWxD unpacked	mm	1760x2850x1320	1760x3450x1320	1760x4050x1320
Crossfolder HxWxD unpacked	mm	-	1010x3430x870	1010x4020x870
Stacker HxWxD unpacked	mm	-	1280x2750x1040	1280x2750x1040
<b>TRANSPORT DATA</b>				
Gross weight	kg	1990	2460	2770
Net weight	kg	1720	2180	2400
Ironer HxWxD packed	mm	1990x2990x1370	1990x3590x1370	1990x4190x1370
Crossfolder HxWxD packed	mm	-	1400x3740x1050	1400x4340x1050
Stacker HxWxD packed	mm	-	1584x3044x1244	1584x3044x1244
Cross-folder net/gross	kg	-	515/760	570/820
Stacker net/gross	kg	-	325/600	325/600

\* The mentioned capacities are only indicated values while the capacity is dependent on the residual moisture, the kind of linen, ironing temperature, pressure of the ironing bed, condition of the surface and the skill of the operators (idem for consumption)

\*\* Compressor not included

1. Feeder button
2. Control panel
3. Upper cover
4. Emergency stop
5. Handle of manual drive
6. Telescopic brushes
7. Exhaust ventilation
8. Filter
9. Electric distributor
10. Suspension eyes
11. Feeding belts
12. Feeder
13. Production label
14. Condense drain (version „S“)
15. Main switch
16. Front trough
17. Steam supply (version „S“)
18. External protective connector
19. Folding table
20. Side cover lock
21. Main power supply
22. Gas supply (version „G“)
23. Pressure air supply
24. Power supply connector for the cross folder
25. Connector for control cable for the cross folder
26. Pressure air connector for the cross folder
27. Power supply connection for the stacker
28. Control cable connection for the stacker
29. Pressure air connection for the stacker
30. Sight glass of burner (version „G“)

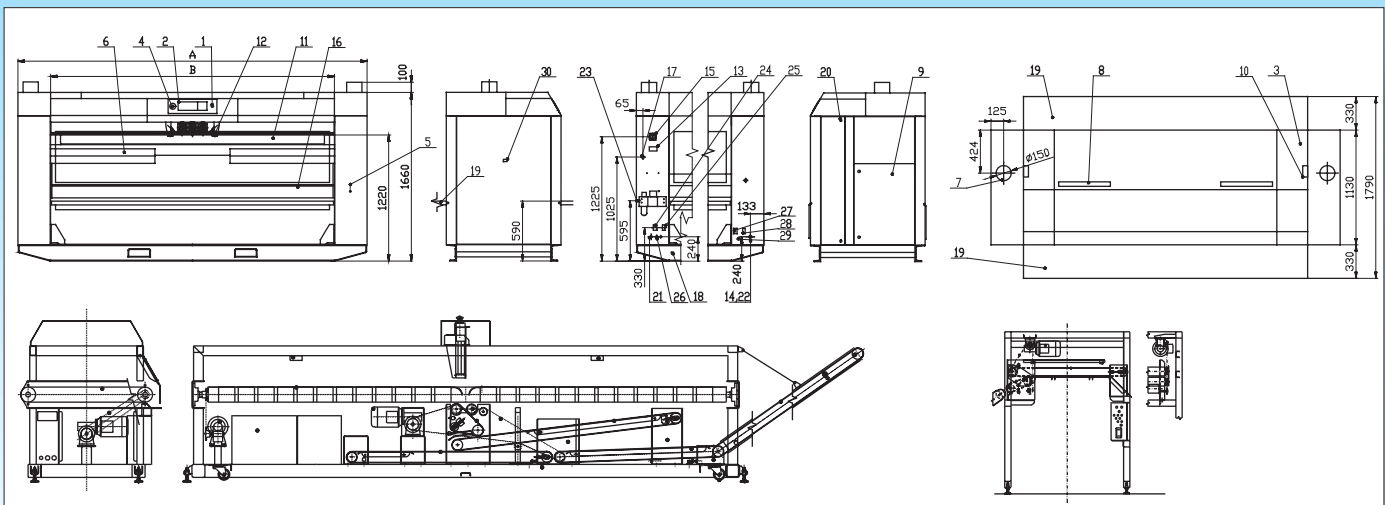

The company Primus bvba preserves the right to change the machines and the specification in this leaflet at any time, without prior notice. Details and photographs are only for information and never binding.

[www.primuslaundry.com](http://www.primuslaundry.com)

primus



Quality without compromise